

REVISIONS			
REV	DESCRIPTION	DATE	APPROVED
--	--	--	--

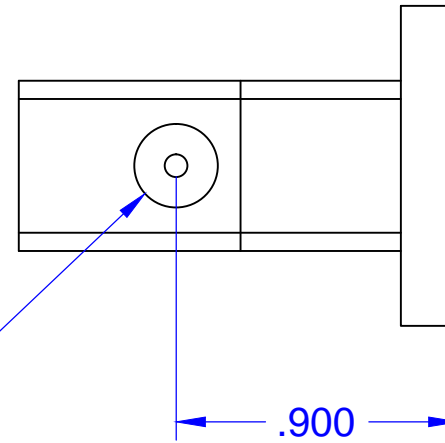

K-FEMALE  
CONNECTOR

WR-34

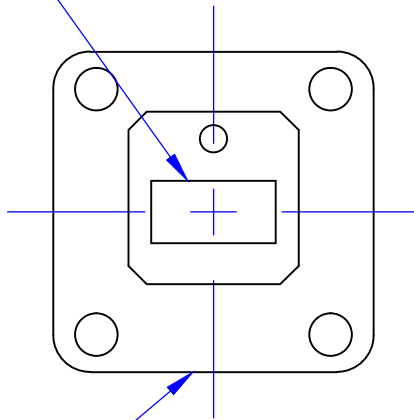

UG 595 FLANGE

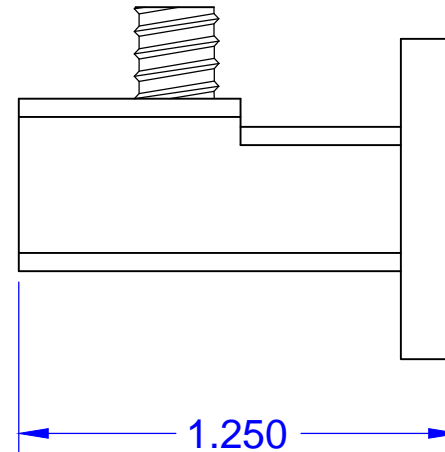

QTY	PART NUMBER	DESCRIPTION		ITEM
--	--	OUTLINE		--
UNLESS OTHERWISE SPECIFIED ALL SURFACES 32/		<p>THIRD ANGLE PROJECTION</p>		
DIMENSIONS ARE IN INCHES TOLERANCES ARE:				
DECIMALS: .1234 +/- .0005 .123 +/- .005 .12 +/- .01				
ANGLES: +/- .5 DEGREES				
ALL THREADS TO BE 2A OR 2B		DATE: 1/2/2013		
REF DWG# --	SHEET NO.	OF	SIZE	DWG NO
ORIGINAL DWG# 20173	1	1	A	20289
		<p><b>Mi-Wave</b> Millimeter Products Inc.</p> <p>TITLE</p> <p><b>410(WR-34)-595/K</b> <b>OUTLINE</b></p>		